



CHAIN AND FLIGHT SCRAPERS

MADE FROM HIGH-TECH
NON-METALLIC MATERIALS



INNOVATIVE COMPLETE SOLUTIONS
ENSURE EVERYTHING RUNS SMOOTHLY

PROBIG®. Clear answers to the challenges of tomorrow.

PROBIG® is the first choice for continuously operating treatment and scraping systems manufactured from high-tech non-metallic materials. We can offer you scraping systems for rectangular tanks up to a maximum of 140 m long and 14 m wide. The range of applications for PROBIG® scraping systems is just as diverse as the growing challenges faced by designers, industries and municipalities all over the world.

PROBIG® develops a perfectly compatible, highly efficient complete solution for every customer. We guarantee flexible implementation of different designs using a variety of materials to suit any application. We also use our exclusive range of chains, sprockets and accessories, which is the largest of its kind worldwide, to implement the most cost-effective modification to existing equipment.

PROBIG® – continuous, unbeatable benefits:

- ISO-certified, ATEX and TUV tested 
- Energy efficient
- Easy maintenance
- Up to 10 times more durable than metal
- Corrosion-resistant
- Low noise
- Short amortisation period
- Durable and reliable



Chains

The PROBIG® range includes non-metallic chains for all tank sizes up to 140 x 14 m, even for highly specialised conveying tasks. Existing systems can easily be retrofitted with PROBIG® chain systems.



Sprockets

PROBIG® chains and sprockets offer optimal durability through high-quality non-metallic material and wear reduction. Sprockets up to max. Ø 4,000 mm are made in accordance with customer requirements.



Flights

GRP flights are available for tank widths of up to 14 m. The accessories available for scraping systems (wear strips, bearings, wear shoes, etc.) guarantee the highest levels of reliability and service life.

Bandräumertypen

4-shaft scraper

For the removal of bottom sludge and floating scum

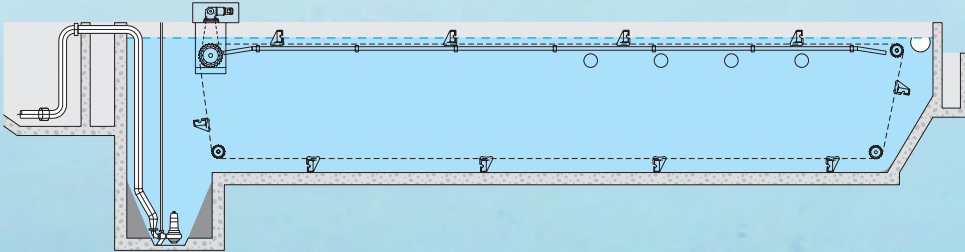

3-shaft scraper

For the removal of bottom sludge

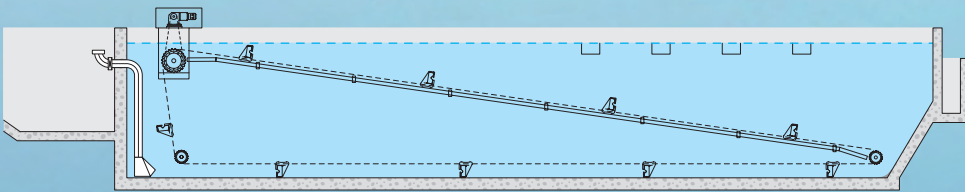

2-shaft scraper

For the removal of bottom sludge

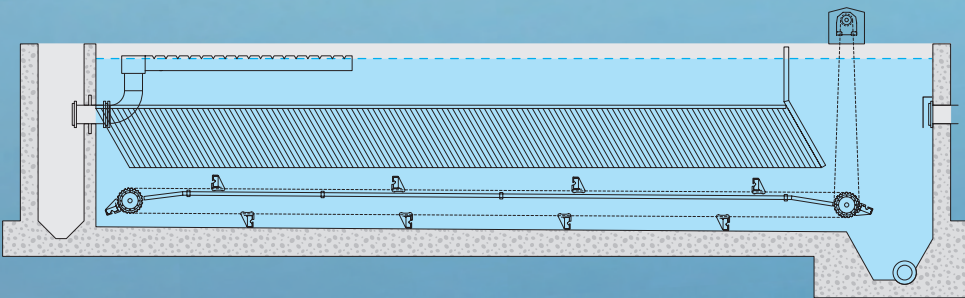

2-shaft scraper

For the removal of floating scum

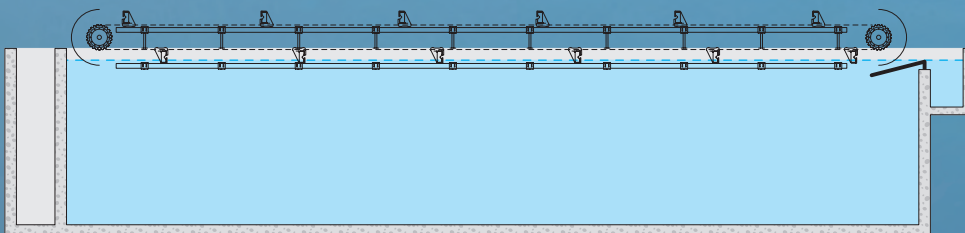

Chain and flight scrapers



Scum pipe

1



Stub shaft

2



GRP return rails with wear shoes

3

9



Wear strips

4



Partitioned bearing supports

5

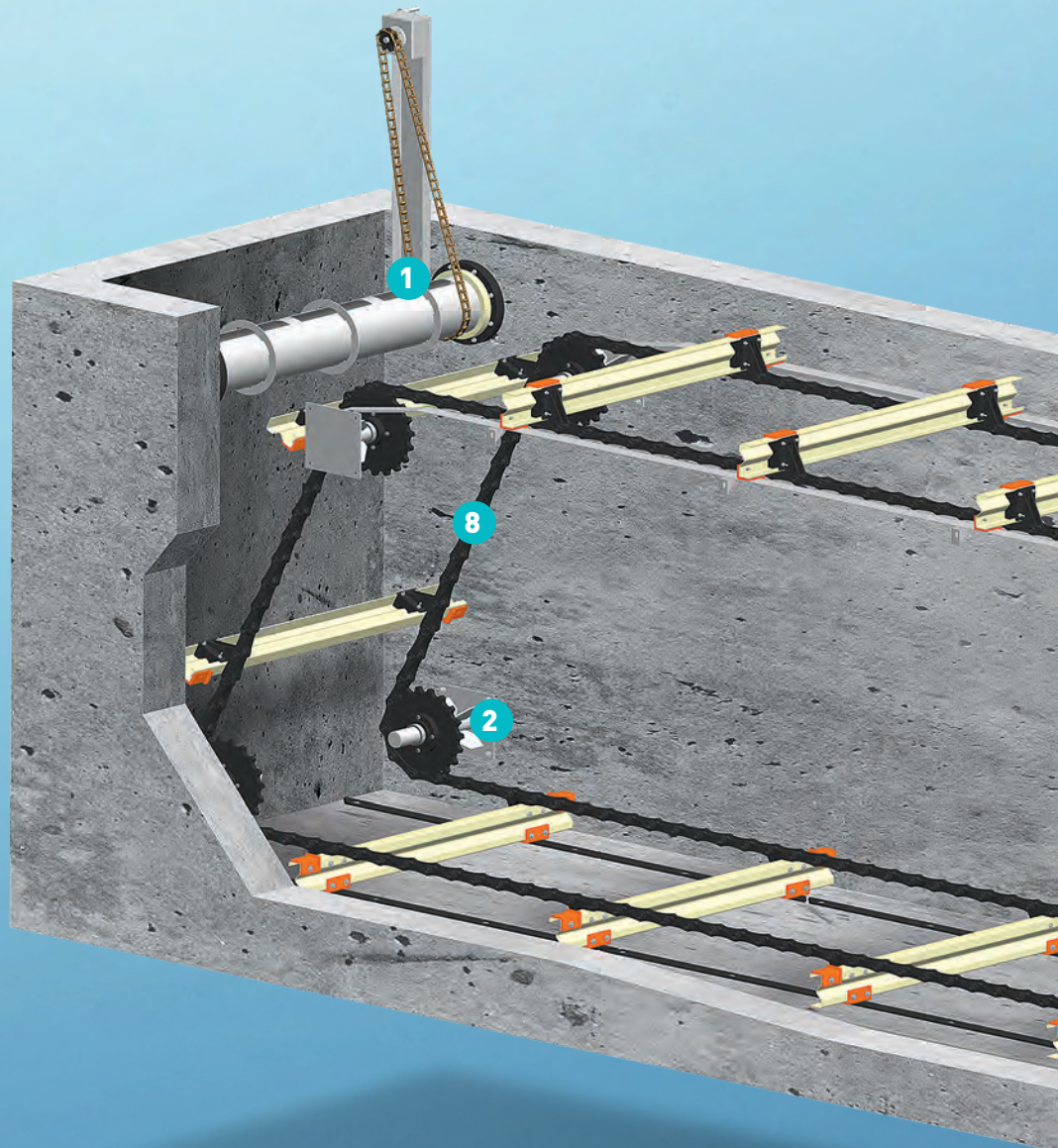

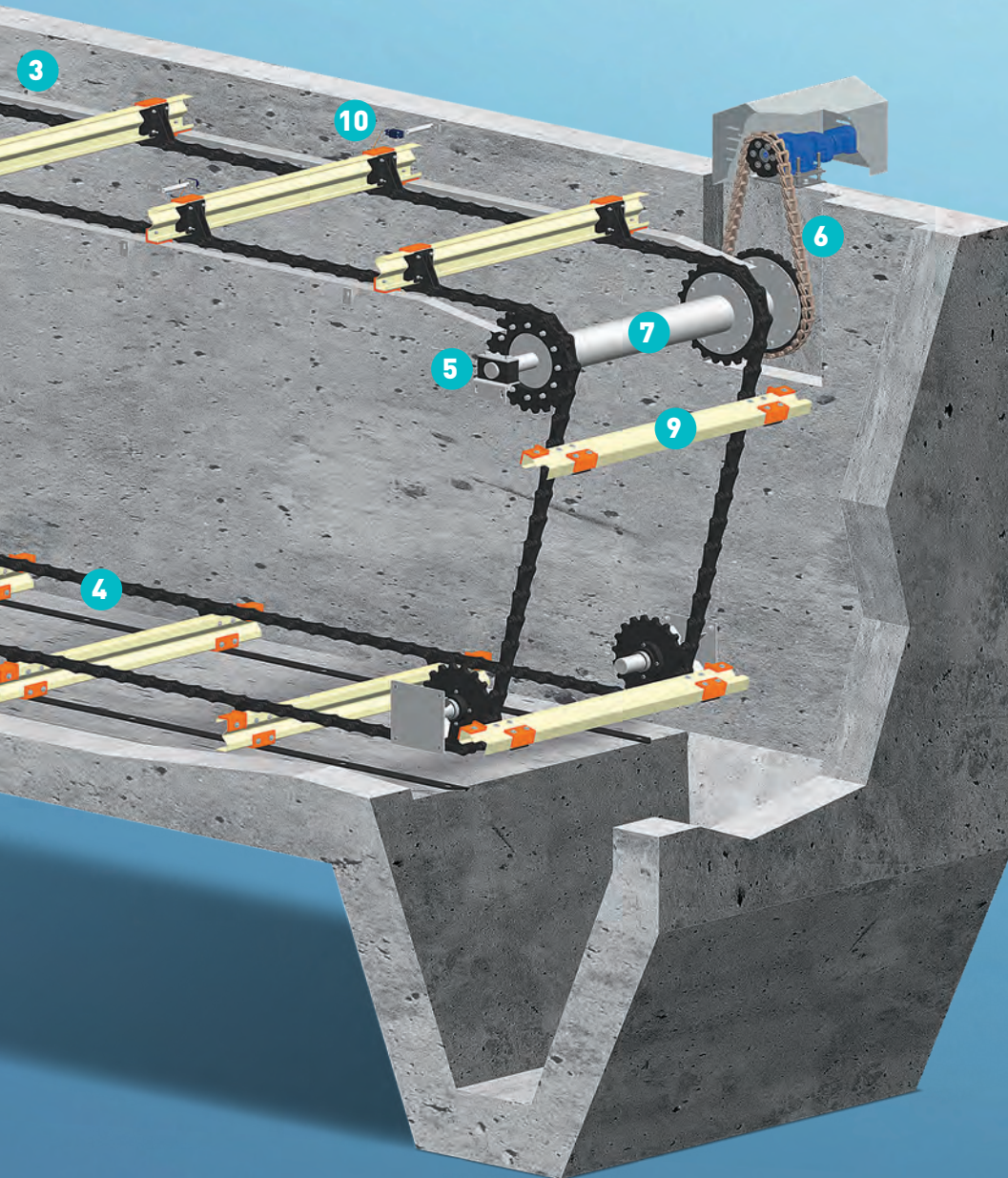

6



Drive units

7



Stainless steel/GRP main shafts

8



Non-metallic chains

10



Flight alignment monitoring system

Innovative technology for the future

CHAINS	DESCRIPTION	MATERIAL	BOLT MATERIAL	PITCH	BREAK LOAD
Conveyor chain	HS730	Continuously wound glass fibres	GRP strand casting with Kevlar rollers	152.4 mm	100 kN
	NCS720S	POM, unfilled	Nylon	152.4 mm	34 kN
Drive chain	NH78	POM	1.4301	66.3 mm	18 kN
	HB78	Stainless steel 1.4000	1.4000	66.3 mm	106 kN
Conveyor/drive chain	NCS360S	POM, unfilled	Nylon	77.0 mm	28 kN
	50	POM/PP/PA	POM/PP/PA	50.0 mm	3 kN/1.5 kN

Standard chains with pitches of 12.7 mm, 19.6 mm and 63 mm are available to buy off-the-shelf.
Specialist chain types of up to 1,000 m, and special materials, e.g. for use at temperatures of up to 220°C, are available on request

SPROCKETS	DESCRIPTION	MATERIAL	PITCH	PITCH CIRCLE Ø
HS730	12 teeth/RL110017	Robalon-S	152.4 mm	588.8 mm
	15 teeth/RLL540-3	Robalon-S	152.4 mm	733.0 mm
NCS720S	19 teeth/RLN134-3	Robalon-S	152.4 mm	468.9 mm
	23 teeth/RLN647	Robalon-S	152.4 mm	564.9 mm
NH78/HB78	11 teeth/RLJ691-3	Robalon-S	66.3 mm	235.3 mm
	28 teeth/RLL717-3	Robalon-S	66.3 mm	592.2 mm
50	7 teeth/RLP686	Robalon-S	50.0 mm	115.6 mm
	16 teeth/RL0019	Robalon-S	50.0 mm	254.2 mm

Special sizes of up to Ø 4,000 mm, as well as construction from other materials, are available on request

BALKEN	DESCRIPTION	MATERIAL	DIMENSIONS	TANK WIDTH
	Ultra high strength SL 280	GRP, polyester/vinylester	280 x 112 x 5.5 mm	up to 14 m
	Ultra high strength SL	GRP, polyester/vinylester	195 x 112 x 3.5 mm	10 to 14 m
	High strength	GRP, polyester/vinylester	191 x 80 x 4 mm	6 to 10 m
	Pro 9	GRP, polyester/vinylester	182.2 x 77.2 x 3.5 mm	up to 6 m

Various special profiles are available on request

ACCESSORIES	DESCRIPTION	MATERIAL
	Filling blocks	Polypropylene
	Wear shoes	UHMW-PE / PU
	Wear strips	Robalon S
	Bearing supports	Robalon S/Robalon Z
	Fixing collars	POM/1.4301/1.4571

SUPPORTING STRUCTURES	DESCRIPTION	MATERIAL
	Main shaft	SS 304/SS 316/Duplex/Super Duplex/GRP
	Stub shaft	SS 304/SS 316/Duplex/Super Duplex/GRP
	Return rails	SS 304/SS 316/Duplex/Super Duplex/GRP
	Motor cover	SS 304/SS 316/Duplex/Super Duplex/GRP
	Motor console	SS 304/SS 316/Duplex/Super Duplex

Special materials can be offered on request

DISCHARGE OF FLOATING SCUM	DESCRIPTION	MATERIAL
	Scum pipe	SS 304/SS 316/Duplex/Super Duplex/GRP
	Paddle system	SS 304/SS 316/Duplex/Super Duplex/GRP
	Screw conveyor	SS 304/SS 316/Duplex/Super Duplex/GRP

All solutions are tailored to meet individual customer requirements

ELECTRICS	DESCRIPTION	
	Drive	0.06 to 0.37 kW
	Flight alignment monitoring system	Mechanical/inductive
	Monitoring relay	Protection against overload and underload

Electrical components are selected to meet the specific requirements of the customer
(components are available from various manufacturers)

Non-metallic special solutions



Non-metallic complete solutions

The best choice for specialised applications: Certified PROBIG® complete solutions made from high-tech non-metallic materials fulfil the most stringent standards in the oil and gas industry, as well as in pre-treatment at seawater plants. Using exclusively developed special non-metallic materials, PROBIG® guarantees chemical-resistant solutions that are suitable for aggressive media.



GRP covers

Perfect protection in great variety: PROBIG® offers a range of diverse, precisely manufactured barrel and flat covers, for example, combined with high-quality scrapers made from high-tech non-metallic materials.



Sludge removal using screw conveyors

The patented solution: Achieve optimal results using screw conveyors! PROBIG® also offers solutions for heavily fluctuating water levels: Up to a total of 250 mm can be automatically levelled. Each PROBIG® solution is flexibly and individually tailored to the customer. Bottom sludge screw conveyors are also available to individual customers depending on the application.



Grit collection scrapers and other special solutions

The high-quality non-metallic chain scrapers from PROBIG® prove effective in all situations where abrasive materials must be removed – even with a high proportion of grit. We offer the ideal special solution for each individual use, such as grit scrapers, screens, trough chain conveyors or scraper conveyors.

Market leaders put their trust in PROBIG®.



Internationally
successful –
globally active.

PROBIG GmbH

Haid 57
4870 Vöcklamarkt
Austria

Tel.: +43 (0) 76 82/22 633-0
Fax: +43 (0) 76 82/22 633-20

office@probig.com
www.probig.com

PROBIG high tech products GmbH

Rupertusstraße 10
83395 Freilassing
Germany

Tel.: +49 (0) 86 54/77 979-0
Fax: +49 (0) 86 54/77 979-33

office@probig.com
www.probig.com

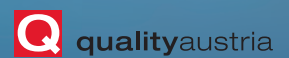

SYSTEM CERTIFIED

ISO 9001:2015 No.06341/0-1
ISO 14001:2015 No.01214/0-1
BS OHSAS 18001:2007 No.00405/0-1

PRO SOLUTIONS FOR
WATER TREATMENT